



Caratteristiche Principali
Principal Features

120 sec

Tempo di lavaggio
Washing time

5.4 Kw

Consumo energetico/h
Energy consumption/h

300 mm

Altezza massima stoviglie
Maximum tableware height

50x50 cm

Dimensione del cesto
Basket size

Punti di forza
Strengths

01 Vasca stampata
Deep drawn tank

02 Accessibilità anteriore
Front accessibility

03 Manutenzione facilitata
Easy maintenance

04 Boiler coibentato
Insulated boiler

05 Doppia parete completa
Double wall - Full

06 Filtro vasca
Washtank filter

Optional



Iniettore
Detergent injector



Predisposizione dosatore detersivo
Predisposition for detergent pump



Dosatore detersivo elettrico
Detergent pump



Pompa scarico interna
Built-in Drain pump



Pompa risciacquo interna
Built-in Boost pump



Depuratore incorporato
Built-in Water softner



Basamento
Stand



Piedi inox +10 cm
Stainless steel feet + 10 cm



Ugelli inox
Stainless steel rinse Jet

Dotazione cesti / Standard basket

4x

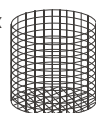

1x



2x

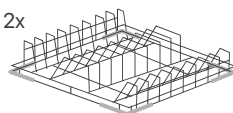

Per approfondimenti vedi scheda Cesti e Accessori
For more information, see the Basket and Accessories section.

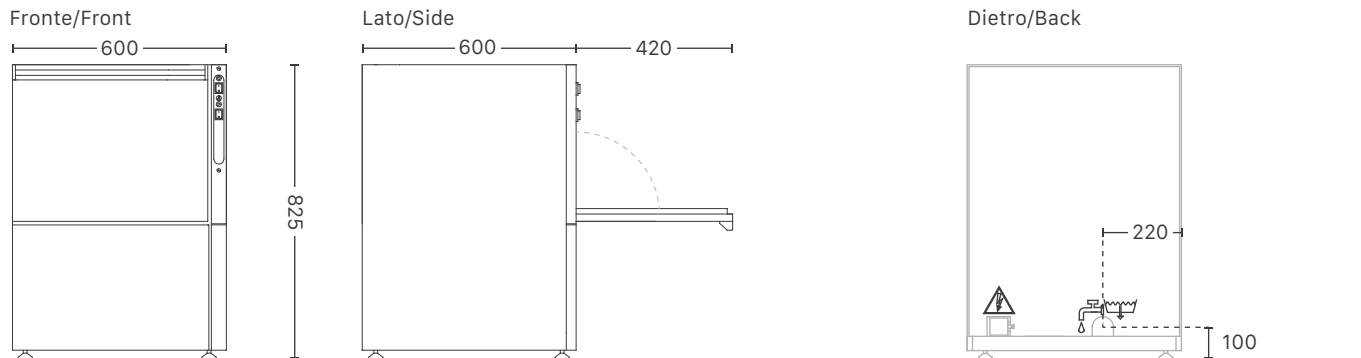

IT	EN	DE	FR	ES	-
Caratteristiche tecniche	Technical features	Technische Merkmale	Caractéristiques techniques	Características técnicas	
Ciclo di lavaggio	Wash/rinse cycle	Spül-/Nachspüldauer	Durée du lavage/rinçage	Ciclo lavado/aclarado	120"
Cesto	Rack	Korb	Panier	Cesto	mm 500x500
Cesto piatti	Platerack	Tellerkorb	Panier assiettes	Cesto platos	22 posti
Alimentazione Elettrica	Electrical supply	Elektroanschluß	Tension d'alimentation	Alimentación eléctrica	400V~3N/50Hz
Resistenza Boiler	Boiler heating element	Boilerheizung	Résistance boiler	Resistencia boyler	W 4500
Resistenza Vasca	Tank heating element	Beckenheizung	Résistance de la cuve	Resistencia cuba	W 3000
Elettropompa	Wash pump	Umwälzpumpe	Pompe de lavage	Electrobomba	Hp 1
Totale Assorbimento	Total rating	Gesamtanschlußwert	Puissance de raccordement	Potencia total absorbida	w 5400
Capacità boiler	Boiler capacity	Boilerinhalt	Capacité du boiler	Capacidad en boyler	6
Capacità vasca	Tank capacity	Tankinhalt	Capacité de la cuve	Capacidad en cuba	21
Consumo acqua 3 bar	Water use at 3 bar	Wasserverbrauch bei 3 bar	Consommation eau a 3 bar	Consumo agua 3 bar	lt/ciclo 3
Pressione acqua alimentazione	Water supply pressure	Fließwasserdruck	Pression eau d'alimentation	Presión agua alimentación	bar mix-max 3-5
Sistema di lavaggio inox	Stainless steel wash arms	Wascharme aus Edelstahl	Bras de lavage en acier inoxydable	Brazos de lavado en acero inoxidable	Superiore e Inferiore

Di serie	Standard	Standard	Standard	Estándar
Caricamento automatico	Automatic filling	Automatische Wasserfüllung	Remplissage automatique	Llenado automatico
Sicurezza porta	Door safety	Türsicherheitsschalter	Sécurité de porte	Seguridad puerta
Doppia parete completa	Double wall - Full	Doppelwand - ganz	Paroi double - Complète	Doble pared - Completa
Boiler coibentato	Insulated boiler	isolierter Boiler	Chaudière isolée	Caldera termoestable
Dosatore brillantante idraulico	Hydraulic rinse-aid pump	Hydraulische Klarspülmitteldosierung	Doseur produit de rinçage hydraulique	Dosificador de abrillantado hidráulico
1 Tubo di carico 3/4" gas	1 3/4" gas water supply hose	1 Wasserzulaufschlauch R 3/4"	1 tuyau d'alimentation eau de 3/4" gas	1 tubo carga 3/4" gas
1 Tubo di scarico Ø 30	1 30 mm Dia water drain hose	1 Abwasserschlauch Ø 30	1 tuyau de vidange Ø 30	1 tubo desague Ø 30
4 Piedini	4 feet	4 FüÙe	4 pieds	4 pies
Filtro vasca	Washtank filter	Beckenfilter	Filtre de la cuve	Filtro cuba

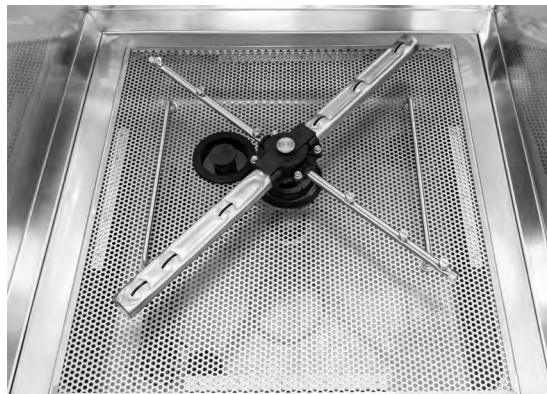

La ditta Univerbar si riserva di modificare senza preavviso le caratteristiche tecniche. / The Univerbar company reserves the right to modify technical characteristics without warning. / La Maison Univerbar se réserve la faculté de modifier, sans préavis, les caractéristiques techniques. / Die Firma Univerbar behält sich das Recht vor, ohne vorherige Benachrichtigung die technischen Eigenschaften zu verändern. / El fabricante Univerbar se reserva el derecho a cualquier modificación sin previo aviso.